

Includes: Hot/Cold Tube, Flow Control Valve, Control Valve, Belt Bracket, Belt and Heat Shield

Function

The HC2400 is NIOSH approved to supply a continuous flow of warm or cool air to Bullard CC20, 88VX, RT and GR50 Series airline respirators. All Bullard parts must be present and properly assembled to constitute a NIOSH-approved respirator.



NOTE

HC2400 cannot be used with a low pressure air source such as an ambient air pump.

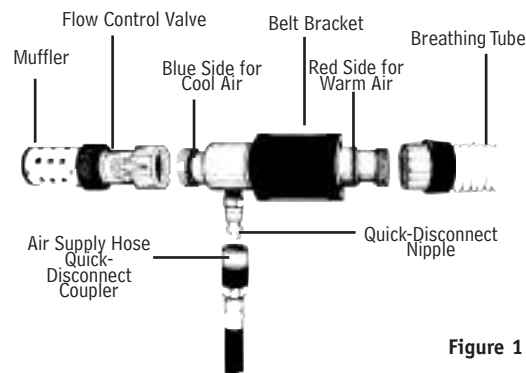

Figure 1

⚠ WARNING

Before using this product read and follow all directions and warnings including those in the respirator instruction manual. Connecting the respirator to a line supplying Nitrogen or other harmful gases could cause death or serious injury.

This climate control system is not recommended for cooling the air supply when the air temperature is less than 70°F (21°C). Since the system may cool the incoming air by more than 30°F (17°C), it is possible for ice to form in the breathing tube and reduce the airflow.

Failure to follow these instructions could result in death or serious injury.

Air Quality, Air Pressure and Air Supply Hose Length Requirements

Air Quality

⚠ WARNING

The respirator's air source must supply clean, breathable air Grade D, or better, at all times. The respirator DOES NOT purify air or filter out contaminants.

Failure to observe this warning could result in death or serious injury.

Respirable air must be supplied to the point-of-attachment of the NIOSH approved Bullard air supply hose. The point-of-attachment is where the air supply hose connects to the fitting that contains a pressure gauge used to monitor the pressure of the air provided to you.

Locate the source of supplied air in a clean environment far enough from your work site to ensure the air remains contaminant-free. Always use an inlet filter on your air source and any monitors and alarms as necessary to assure clean, breathable air at all times.

Supplied breathing air MUST meet or exceed the requirements for Type 1 gaseous air described in the Compressed Gas Association Commodity Specification G-7.1 (Grade D or higher quality) as specified by Federal Law 42 CFR, Part 84, Subpart J, 84.141(b).

- The requirements for Grade D breathable air include:
- Oxygen19.5-23.5%
 - Hydrocarbons (condensed) in mg/m³ of gas5 mg/m³ max.
 - Carbon monoxide10 ppm max.
 - Carbon dioxide1,000 ppm max.
 - Odor No detectable odor
 - No toxic contaminants at levels that make air unsafe to breathe.

Refer to C.G.A. Commodity Specification G-7.1 for complete details, or contact the Compressed Gas Association (1235 Jefferson Davis Highway, Arlington, VA 22202).

Air Pressure

Continually monitor the air pressure at the point-of-attachment while operating the respirator. A reliable air pressure gauge must be present to monitor the pressure.

⚠ WARNING

Failure to supply the minimum required pressure at the point-of-attachment for your hose length will reduce airflow and could result in death or serious injury.

It is important to operate the Bullard climate control device in the prescribed pressure range for the particular Bullard respirator you are using. Operating the correct pressure range will insure that the correct air flow is delivered to the respirator and will maintain the NIOSH approval. Refer to your respirator user manuals' Breathing Air Pressure Table to determine the correct pressure that should be used with the climate control device. This table defines the pressure ranges necessary to provide the respirator with a volume of Grade D air that falls within the U.S. Government required range of 6-15 cfm (or 170-425 lpm). (See 42 CFR, Part 84, Subpart J, 84.150)

The **Breathing Air Pressure Table** defines the air pressure ranges necessary to provide the CC20, 88VX, RT or GR50 Series respirator with a volume of air that falls within the required range of 6-15 cubic feet per minute (cfm) or 170-425 liters per minute (lpm).

Be sure you understand the information in the **Breathing Air Pressure Table** before using the respirator. To use the table, follow the steps identified below:

1. Confirm the air source and climate control device .
2. Confirm your choice of NIOSH approved Bullard air supply hose(s) to use with your Cool Tube.
3. Determine that your air supply hose does not exceed the maximum approved hose length or number of hose sections.
4. Set the air pressure at the point-of-attachment within the required pressure range for your air supply hose length.

Air Supply Hose

To maintain your Bullard respirator's NIOSH approval, use only approved Bullard V10 Series hose(s) in lengths of 25 to 300 feet (7.62m-91.4m), or Bullard V5 Series hose in lengths of 25 feet (7.6m) or 50 feet (15.2m), between the Hot/Cold Tube's quick-disconnect fitting and the point-of-attachment to the hose. Bullard V11 hose-to-hose adaptors **MUST** be used to connect V10 hose lengths together. Secure connection(s) until wrench tight and leak free.

Use of any other air supply hose voids NIOSH approval of the entire respirator assembly and could reduce the airflow to the respirator, possibly resulting in serious injury or death to the respirator wearer.

⚠ WARNING

Before connecting the Hot/Cold Tube to the respirator, be sure the breathing air at least meets the minimum Grade D requirements. (See **Air Quality** section on front page.)

Compressed air must be dry enough to prevent ice buildup in the cold airstream. Ice could reduce airflow into the respirator hood. Failure to observe these warnings could result in death or serious injury.

Preparation and Use of the HC2400

1. For Warm Air:

- In an uncontaminated atmosphere screw the nylon hose connector on the end of the breathing tube onto the RED side of the HC2400 Tube.
- Screw the flow control valve and muffler onto the blue side of the HC2400 Tube (Figure 1). Tighten both connections firmly.

For Cool Air:

- In an uncontaminated atmosphere unscrew the nylon hose connector on the end of the breathing tube from the hose threads on the RED side of the HC2400 Tube.
- Unscrew the muffler and flow control valve from the blue side of the Hot/Cold Tube. Then screw the flow control valve and muffler to the RED side. Tighten firmly.
- Screw the nylon hose connector on the end of the breathing tube onto the BLUE side of the HC2400 Tube (Figure 1). Tighten firmly.

⚠ WARNING

For adequate air flow, attach the muffler and flow control valve to the end of the hot/cold tube that is opposite the breathing tube end. Failure to observe this warning could result in death or serious injury.

DO NOT USE THE HC2400 WITHOUT THE MUFFLER AND FLOW CONTROL VALVE.

- Lace the belt supplied with the HC2400 through the belt bracket. Slots are provided for wearing the tube either vertically or horizontally on the waist. See Heat Shield instructions below
- With the approved Bullard air supply hose connected to the air source and with air flowing into the hose, connect the quick-disconnect coupler on the air supply hose to the quick-disconnect nipple on the Hot/Cold Tube.
- Adjust the air pressure at the point-of-attachment (Figure 2) to within the approved pressure range. See the Respirator Breathing Air Pressure table in the respirator user manual.
- Put the hood on by following the directions in your respirator instruction manual. If you do not have instructions, contact Bullard Customer Service at the address or phone numbers below.
- Turn flow control valve to adjust the flow and temperature of incoming air (Figure 1).

Maximum cooling or warming is attained when knob is fully open and when there is maximum airflow out of the HC2400 exhaust port.

Bullard
1898 Safety Way
Cynthiana, KY 41031-9303
Toll free: 877-BULLARD (285-5273)
Tel: 859-234-6616
Fax: 859-234-8987
www.bullard.com

Bullard GmbH
Lilienthalstrasse 12
53424 Remagen
Germany
phone: 0049-2642 999980
fax : 0049-2642 9999829
www.bullardextrem.com

Bullard Asia Pacific Pte. Ltd.
LHK Building
701, Sims Drive, #04-03
Singapore 387383
Tel: (65) 6745-0556
Fax: (65) 6745-5176
www.bullard.com

To obtain air that is closer to ambient temperature, turn air temperature control knob counterclockwise. If knob is fully closed, your respirator will receive air at ambient temperature.

- When finished working, leave the work area wearing the respirator. With the air still flowing into the hood, remove the hood and then disconnect the air supply hose using the quick-disconnect coupler attached to the Hot/Cold Tube.

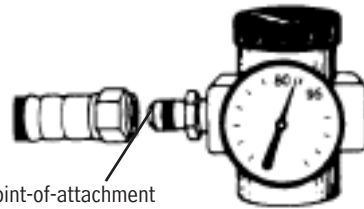

Figure 2

Heat Shield Instructions

The climate control heat shield is designed to work with the Bullard AC1000, HC2400, or ACL99 climate control devices.

Assembly

The heat shield is designed to work with the standard nylon belt (part # 4612) supplied with the climate control devices.

- Determine whether the climate control device will be worn vertically or horizontally on the waist.
- If the device will be worn in the horizontal position, align the tube on the heat shield as shown in Figure 3. If the tube will be worn in the vertical position, align the tube on the heat shield as shown in Figure 4.
- Lace the belt supplied with your climate control device through both the heat shield slots and the climate control belt bracket slots.

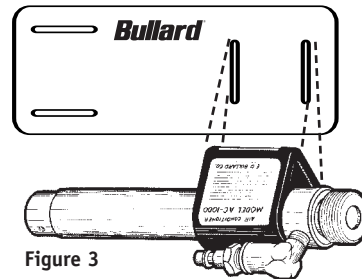

Figure 3

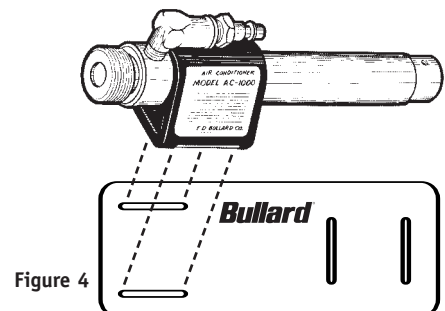

Figure 4